



evolution
EVC-P PHOTOELECTRIC SMOKE DETECTOR
INSTRUCTION MANUAL

Ref No: **NISM/EVC-P/01**

DATE: **NOV 2003**

PAGE:
1 of 6

ISSUE: **01**

evolution.....

*The **EVC-P** Photoelectric Smoke Detector forms part of a brand new range of fire detectors from Nittan (UK) Ltd called **evolution**.*

*The **EVC-P** is an elegantly designed, low profile detector which is aesthetically pleasing, thus enabling it to blend unobtrusively into modern working environments.*

*The **EVC-P** is compatible with other existing conventional fire detection systems.*



evolution
EVC-P PHOTOELECTRIC SMOKE DETECTOR
INSTRUCTION MANUAL

Ref No: **NISM/EVC-P/01**

DATE: **NOV 2003**

PAGE: **2 of 6**

ISSUE: **01**

CONTENTS:-

Section 1	- Introduction	- Page 2
Section 2	- Operation	- Page 2
Section 3	- Detector Models	- Page 3
Section 4	- Base Models	- Page 3
Section 5	- Installation	- Page 3
Section 6	- Maintenance & Cleaning	- Page 3
Section 7	- Specification	- Page 4
Section 8	- Environmental Parameters:-	- Page 5
	- Temperature	- Page 5
	- Humidity	- Page 5
Section 9	- EMC	- Page 5
Section 10	- Connections	- Page 6
Section 11	- Dimensions	- Page 6

Section 1 - INTRODUCTION

The EVC-P is an attractively-styled, low profile photoelectric smoke detector for use in conventional fire detection systems.

The EVC-P has a chemically etched, stainless steel insect screen therefore reducing the ingress of insects and airborne contaminants.

EVC-P features:

***Optical detector, detecting visible particles of combustion**

***Low profile, stylish appearance**

***Supplied with protective dust cover, (remove during commissioning)**

***Non-polarised terminals**

***Unauthorised head removal signal facility**

***Low monitoring current**

***Patented OMNIVIEW™ 360° LED fire alarm indicator**

***Remote indicator output**

***Compatible with STB-4, STB-4SD and STB-4SE bases**

Section 2 - EVC-P OPERATION

The smoke chamber of the EVC-P is constructed so that light cannot enter from outside, but smoke can pass through the chamber slots. The EVC-P utilises the light scatter sensing principle. The LED pulses every 8 seconds to maintain a low monitoring current. A quick charge time (20 seconds) is also achieved. The detector incorporates an alarm verification function which requires two successive pulses before an alarm is given.

The interval between the first and second pulse is automatically reduced to four seconds after the first alarm level is monitored. The detector design provides strong immunity to air velocities, contamination and RF interference.

The geometry of the smoke chamber and optics support assembly is designed to give the best possible signal to noise ratio, resulting in excellent response characteristics.



evolution
EVC-P PHOTOELECTRIC SMOKE DETECTOR
INSTRUCTION MANUAL

Ref No: **NISM/EVC-P/01**

DATE: **NOV 2003**

PAGE: **3 of 6**

ISSUE: **01**

Section 3 - DETECTOR MODELS

The EVC-P photoelectric smoke detector is supplied, as standard, with four terminals.

The EVC-P has the facility to activate a remote LED indicator or auxiliary function, as standard.

The terminals on the EVC-P detector head are configured as follows:-

Terminal 3 = zone positive in/out

Terminal 1 = zone negative in

Terminal 6 = zone negative out

Terminal 5 = 20 mA @ 24V d.c. switched output

Section 4 - BASE MODELS

A variety of bases are available for use with the EVC-P detector. It is important to use the correct base for each application. The standard range available is as follows:-

i) STB-4 base: having 4 terminals, for standard use with EVC-P detector including the auxiliary output function.

ii) STB-4SD base: This is identical to the standard STB-4 base, but also includes a schottky diode for head removal fault monitoring. The schottky diode is used in some fire systems to ensure power is maintained, in the event of an unauthorised detector head removal, to other detectors further on the zone.

iii) STB-4SE base: Similar to STB-4 base, except deeper.

iv) STB-4SE-24VR base: Relay contact base.

Section 5 - INSTALLATION

In normal use, the EVC-P detector will be installed at ceiling level. Pass the field wiring through the cable hole in the centre and from the rear of the base. Offer up and affix the base to the ceiling or conduit fitting with screws via the base mounting holes. Connect the field wiring to the base terminals, as detailed on page 6 making sure the wiring does not obstruct fitting of the detector head. Fit the detector head by inserting it into the base and turning clockwise until the notch in the detector rim aligns with base locking screw. The OMNIVIEW™ 360° indicator permits visibility from any angle.

Fit the plastic dust cover supplied over the detector to keep out dust etc, until the system is commissioned. If the dust cover is not fitted and the environment is slightly dusty, such as when building work is being completed, for example, problems of false alarms are likely to occur after commissioning unless cleaning of the detector is undertaken. At commissioning, the dust cover should be removed and discarded.

NOTE: THE PLASTIC DUST COVER MUST BE REMOVED FROM THE DETECTOR IN ORDER FOR THE DETECTOR TO FUNCTION CORRECTLY.

Section 6 - MAINTENANCE AND CLEANING

Maintenance:

The EVC-P detector is a high quality product engineered for reliability. In order to obtain optimum performance, periodic maintenance is required. If proper preventative maintenance is not carried out, there is a likelihood of malfunction, as a dirty detector is more likely to cause a false alarm.

Servicing:

Servicing of the system should be carried out in accordance with the requirements of BS 5839 Part 1, Fire Detection and Alarm Systems for Buildings: Code of Practice for System Design, Installation and Servicing.

The maintenance procedures described below should be conducted with the following frequency:

One month after installation: Routine Inspection and every 3 months thereafter.

Every 6 months: Operational Test

Every 12 months: Functional Test and Cleaning.

All above frequencies of maintenance are dependent on ambient conditions.

Routine Inspection:

i) Ensure the detector head is secure and undamaged.

ii) Check the smoke entry apertures are in no way obstructed.

iii) Ensure the surface of the detector's outer cover is clean. If there are deposits due to the presence of oil vapour, dust etc, then the detector should be cleaned in accordance with the cleaning instructions detailed later in this manual. It may be advisable to ensure that such cleaning is conducted regularly in the future.

iv) Ensure no equipment which may generate combustion products or fine airborne particles, has been installed in the vicinity of the detector since the last routine inspection. If such equipment has been installed, then you should notify the Fire Safety Officer or other competent authority that its presence may cause false alarms.



evolution
EVC-P PHOTOELECTRIC SMOKE DETECTOR
INSTRUCTION MANUAL

Ref No: **NISM/EVC-P/01**

DATE: **NOV 2003**

PAGE: **4 of 6**

ISSUE: **01**

Operational Test:

The purpose of the Operational Test is to confirm the detector's correct operation in response to a smoke condition.

i) Take any necessary precautions at the control panel to limit the sounding of the alarm sounders/bells and any fire service summoning device.

ii) Introduce a discrete amount of smoke into the detector head, e.g. using a 'No Climb -Solo' smoke test head. Check that the detector gives an alarm condition within 15 seconds. Check the LED indicator on the EVC-P detector illuminates and any remote indicator LED fitted also illuminates.

iii) After the detector has given the alarm condition, reset the detector from the control panel. It may be necessary to allow a short time to elapse before resetting the detector, to allow any residual smoke from the test to disperse.

iv) Before proceeding to the next detector, ensure that the detector just tested does not re-operate due to the presence of residual smoke.

Functional Test:

The detector may be returned to Nittan (UK) Ltd for functional testing.

Cleaning:

Note: The detector head should NOT be disassembled.

i) Carefully remove the detector head from its base.

ii) Use a soft, lint-free cloth, moistened with alcohol for sticky deposits, to clean the plastic casing.

iii) Using a soft bristle brush (e.g. an artist's paint-brush) carefully brush between the vanes in a linear motion away from the smoke entry apertures.

iv) It is permissible to blow dust from the chamber, without removing the cover, using a clean air line.

v) If the unit needs further cleaning, or is damaged or corroded, please return the complete detector to Nittan (UK) Ltd. for service.

Section 7 - SPECIFICATIONS

Model Reference:	-	EVC-P
Computer Reference:	-	F02N82200
Detector Type:	-	Photoelectric smoke detector
Sensitivity	-	3% Obscuration per metre
Supply Voltage:	-	24V dc nominal (range 20V to 28V)
Voltage Ripple:	-	20% maximum
Alarm Characteristics:	-	6V d.c. in series with 375R between +(terminal 3) and -(terminals 1,6) at 25 deg. C
Monitoring Current:	-	40 μ A max. at 24V d.c.
Alarm Current:	-	50 mA. max.
Charging Time:	-	20 seconds
Ambient Temperature Range:	-	-10 °C to +55 °C
Standard:	-	EN54-7:2000
EMC Conformance:	-	BS EN50130-4:1996 (Immunity) BS EN61000-6-3:2001 (Emissions)
Mass:	-	118g (excluding base)
IP Rating:	-	41



evolution
EVC-P PHOTOELECTRIC SMOKE DETECTOR
INSTRUCTION MANUAL

Ref No: **NISM/EVC-P/01**

DATE: **NOV 2003**

PAGE:
5 of 6

ISSUE: **01**

**Section 8 - ENVIRONMENTAL
PARAMETERS**

Temperature Considerations:

Over the range from -10°C to +55°C.

Humidity:

Relative Humidity of up to 95%, measured at 50°C, non condensing.

Section 9 - EMC

Installation

The installation shall be in accordance with the regulations either of the approval body for an approved system, or otherwise, to the national code of practice/regulations for the installation of the fire alarm system, e.g. BS 5839 part 1.

Electromagnetic Compatibility (EMC)

On a site where there is an unusually high level of potential electrical interference, e.g. where heavy currents are being switched or where high levels of R.F. are prevalent, care then must be taken in the type and routing of cables. Particular care should be given to the separation of zone wiring from the cable carrying the interference.



evolution
EVC-P PHOTOELECTRIC SMOKE DETECTOR
INSTRUCTION MANUAL

Ref No: **NISM/EVC-P/01**

DATE: **NOV 2003**

PAGE: **6 of 6**

ISSUE: **01**

Section 10 - CONNECTIONS

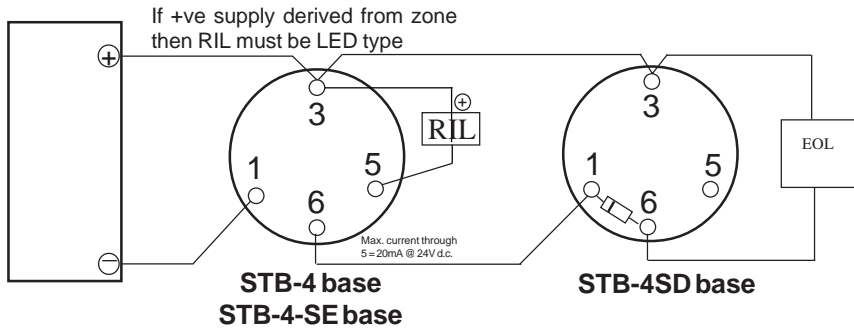

RIL must be 6V, 20mA max.

Section 11 - DIMENSIONS

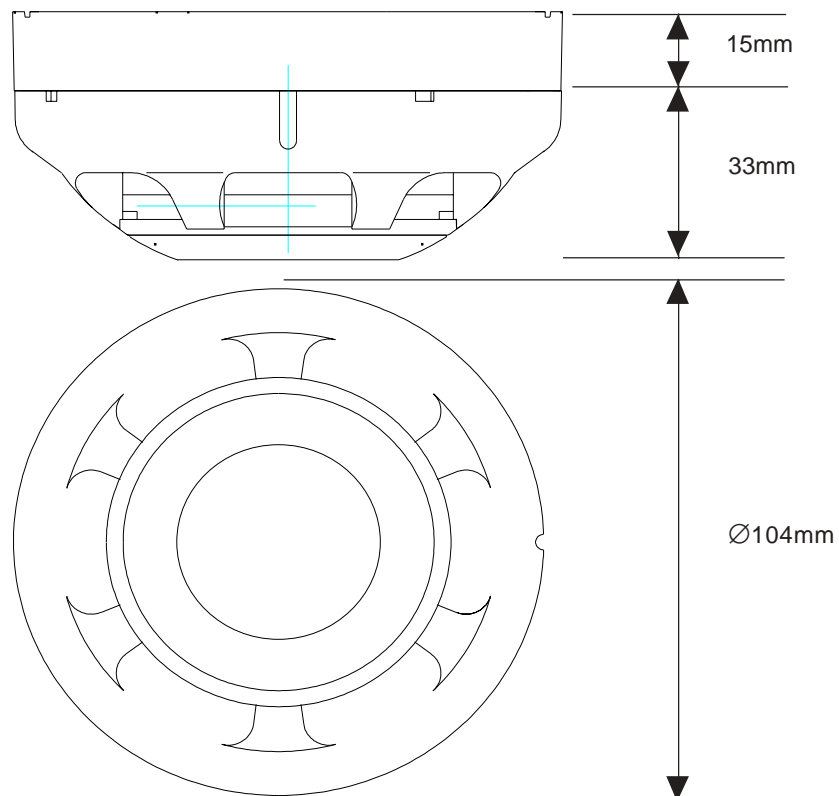



Document No. **NISM/EVC-P/01**
Date **NOV 2003**

evolution

EVC-P CONVENTIONAL PHOTOELECTRIC SMOKE DETECTOR INSTRUCTION MANUAL



LPCB REF: 041f/03



Quality System Certificate No. 041
Assessed to BS EN ISO 9001:2002

NITTAN (UK) LTD. 

Hipley Street, Old Woking, Surrey, England, GU22 9LQ. UK

Tel: +44 (0) 1483 769555 Fax: +44 (0) 1483 756686 Web Site: www.nittan.co.uk E-mail: sales@nittan.co.uk