

LOW PROFILE ANALOGUE ADDRESSABLE TEMPERATURE SENSORS MODELS 5251EM, 5251HTEM AND 5251REM

PART OF THE *series* FAMILY

200^{PLUS}

FEATURES

- Compatible with existing System Sensor protocol
- Microprocessor controlled to give a rapid and linear response
- Panel selectable static sensitivity settings (58°C or 78°C)
- Extended Temperature range
- Stable communication with high noise immunity
- Twin LED indicators providing 360° visibility
- Rotary decade address switches
- Tamper-Resistant (standard feature)
- Built in test switch
- Third party certified to EN54-5:2000

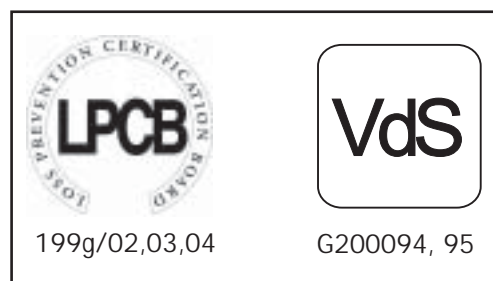

DESCRIPTION

The 5251 range of static element and "rate of rise" temperature sensors provide solutions for a wide range of applications.

The 5251EM and 5251HTEM are fixed temperature analogue addressable sensors employing low mass thermistors and microprocessor technology for fast response and linear temperature sensing. Their linear response allows these sensors to be used to signal temperatures over the range of 58°C (Class A1S) to 78°C (Class BS).

The 5251REM uses the same thermistor and microprocessor technology to provide an alarm when the rate of rise in temperature exceeds 10°C/minute (typical) or if the temperature exceeds a threshold of 58°C (Response Class A1R).

All of the 5251 detectors have two integral alarm LEDs which provide local visual indication of the sensor status. These LED's provide a dual function. In the event on an alarm, they are switched ON continuously, and can also be programmed to either blink when polled by the panel or remain off during normal conditions. In addition to its integral LEDs, the 5251EM can be connected to a Remote LED indicator (standard feature).

The individual loop address of each 5251EM can be easily set and read, using the rotary decade address switches located on the rear of each sensor. The use of decimal address codes significantly reduces the potential for incorrect address selection.

Each sensor base includes a tamper resistant option which, when activated, prevents the removal of the sensor from its base without the use of a tool. Full circuit functionality can be easily confirmed on site by use of the sensor test switch. Operation of this magnetic switch will generate an alarm response to the fire alarm control panel, making system testing both convenient and simple.

All System Sensor products are covered by our extended 3 year warranty.

EUROPEAN HEADQUARTERS
SYSTEM SENSOR EUROPE
 3 HORSHAM GATES
 HORSHAM
 WEST SUSSEX
 RH13 5PJ
 UNITED KINGDOM
 TEL: +44 (0)1403 276500
 FAX: +44 (0)1403 276501
 EMAIL: sales@sseuk.com

EUROPEAN MANUFACTURING CENTRE
PITWAY TECNOLOGICA SPA
 VIA CABOTO 19/3
 34147 TRIESTE
 ITALY

TEL: +39 040 9490111
 FAX: +39 040 382137

www.systemsensoreurope.com



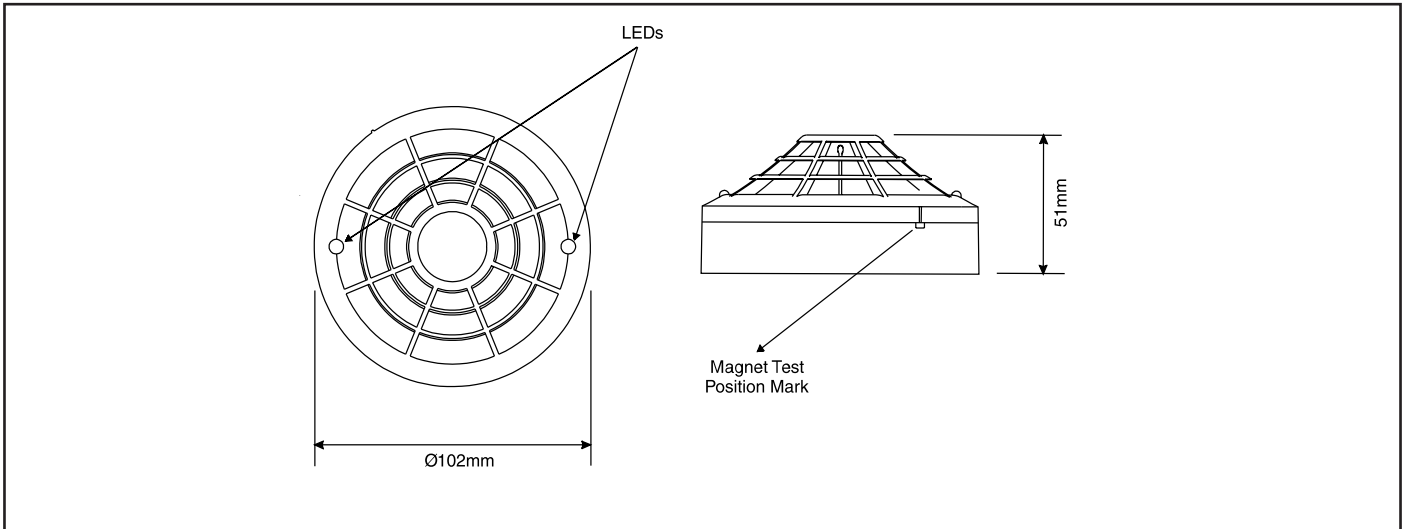

5251EM, 5251HTEM & 5251REM THERMAL SENSORS

SPECIFICATIONS

Response Classification

5251EM	Class A1S
5251REM	Class A1R
5251HTEM	Class BS

Electrical

Operating Voltage Range	15 to 32VDC
Maximum Standby Current	200µA at 24VDC (no communications)
Maximum Average Standby Current	300µA (One Communication each 5 seconds with LED blink enabled)
Maximum Alarm Current (LED On)	7mA at 24VDC

Environmental

Operating Temperature Range	-30°C to 80°C
Humidity	10 to 93% Relative Humidity (non-condensing)

Mechanical

Height	51mm installed in B501 base
Diameter	102mm installed in B501 base
Weight	102g
Max Wire Gauge for Terminals	2.5mm ²
Colour	Pantone Warm Grey 1C
Material	Bayblend FR110

Product Range

Compatible Bases	B501, B501DG, B524IEFT, B524IE, B524RLY
Other Devices in range	Refer to other Series200 <i>plus</i> datasheets

Notes:

1. For Class A1S and A1R Sensors maximum ambient temperature should not exceed 45°C to avoid unwanted alarm conditions being triggered.
2. For Class BS Sensor maximum ambient temperature should not exceed 68°C to avoid unwanted alarm conditions being triggered.