

LOW PROFILE ANALOGUE ADDRESSABLE MULTI-CRITERIA FIRE SENSOR MODEL 2251TEM

PART OF THE *series* FAMILY

200^{PLUS}

FEATURES

- Compatible with existing System Sensor protocol
- Microprocessor controlled with internal algorithms
- Enhanced signal processing for improved stability
- High immunity to unwanted alarms
- 2 auto-learn sensitivity settings
- 3 fixed sensitivity photo-thermal settings
- Thermal-only mode for day/night applications
- Automatic drift compensation
- Twin LED indicators providing 360° visibility
- Extended temperature range
- Built in test switch
- Stable communication with high noise immunity
- Third party certified to CEA 4021, EN54-7:2000 and EN54-5:2000

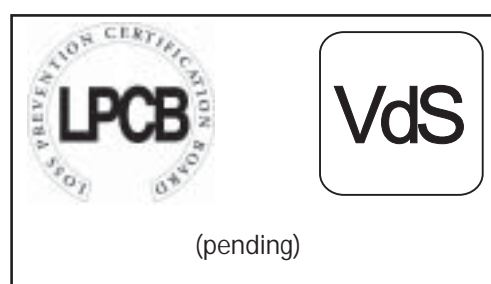

DESCRIPTION

The 2251TEM Multi-Criteria Fire Sensor is a plug in fire detector combining optical smoke detection, heat detection and microprocessor control with Analogue Addressable communications.

For smoke detection, the 2251TEM incorporates an improved design of sensing chamber, linked to sophisticated processing circuitry incorporating smoothing filters to help eliminate transient environmental noise conditions, which can be the cause of unwanted alarms.

The detector's performance is further enhanced by the integration of special algorithms, which automatically compensate for contamination of the sensing chamber, hence providing consistent level of sensitivity and increased immunity to unwanted alarm conditions. Should the maximum compensation range be exceeded the detector will generate a unique signal to the fire alarm control panel indicating a requirement for maintenance.

The thermal detection function features single thermistor technology with a linear temperature response.

Special algorithms are used to process the inputs from both optical and thermal functions, before an alarm decision is made.

In addition to the standard fixed alarm thresholds, the detector can be programmed to operate using an "Auto-learn" feature. When operating in this mode the sensitivity of the detector will automatically adjust to short term changes in its environment, reducing the potential for unwanted alarms occurring through local activities with the protected space. In areas where the normal daytime activities are likely to create unwanted alarms, the detector can be programmed to operate in a "Heat only" mode, automatically reverting to optical-thermal operation during the unoccupied period. The 2251TEM is thus able to offer performance flexibility coupled with superior environmental stability.

The 2251TEM has two integral RED LEDs which provide local visual indication of the sensor status. These LED's provide a dual function. In the event on an alarm, they are switched ON continuously, and can also be programmed to either blink when polled by the panel or remain off during normal conditions. In addition to its integral LEDs, the 2251TEM can be connected to a Remote LED indicator (standard feature).

EUROPEAN HEADQUARTERS
SYSTEM SENSOR EUROPE
3 HORSHAM GATES
HORSHAM
WEST SUSSEX
RH13 5PJ
UNITED KINGDOM
TEL: +44 (0)1403 276500
FAX: +44 (0)1403 276501
EMAIL: sales@sseuk.com

EUROPEAN MANUFACTURING CENTRE
PITWAY TECNOLOGICA SPA
VIA CABOTO 19/3
34147 TRIESTE
ITALY

TEL: +39 040 9490111
FAX: +39 040 382137

www.systemsensoreurope.com



2251TEM PHOTO-THERMAL DETECTOR

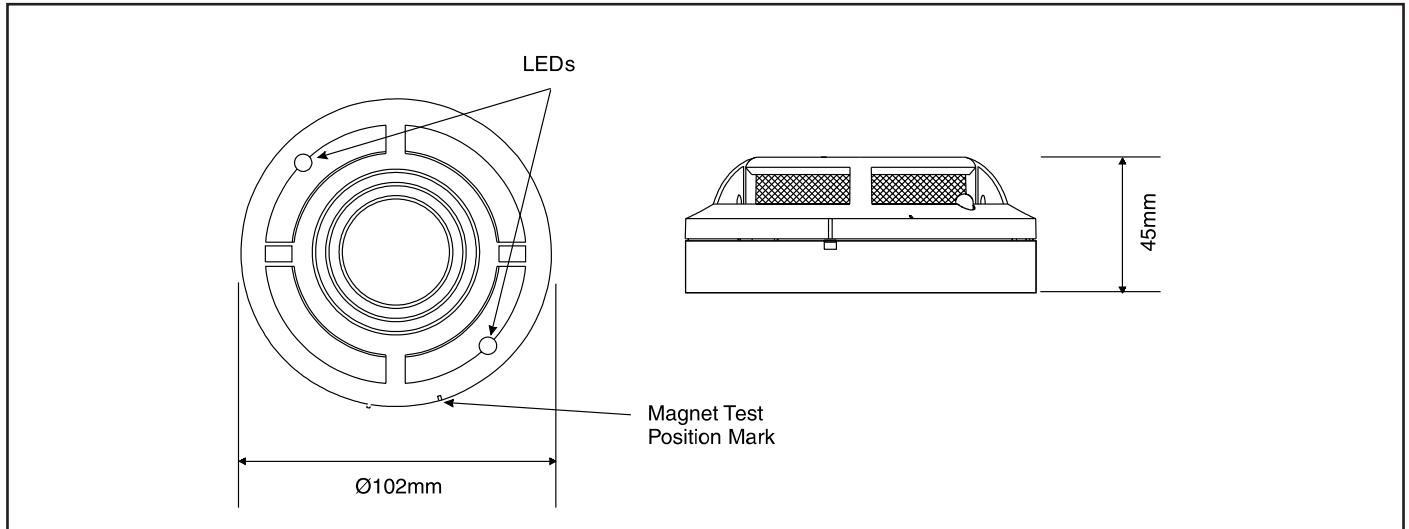

Each sensor base includes a tamper resistant option which, when activated, prevents the removal of the sensor from its base without the use of a tool. Full circuit functionality can be easily confirmed on site by use of the sensor test switch. Operation of this magnetic switch will generate an alarm response to the fire alarm control panel, making system testing both convenient and simple.

All System Sensor products are covered by our extended 3 year warranty.

SPECIFICATIONS

Electrical

Operating Voltage Range	15 to 32VDC
Maximum Standby Current	200µA at 24VDC (no communications)
Max Average Standby Current	300µA (One communication each 5 seconds with LED blink enabled)
Maximum Alarm Current (LED On)	7mA at 24VDC

Environmental

Operating Temperature Range	-30°C to 80°C
Humidity	10 to 93% Relative Humidity (non-condensing)

Mechanical

Height	45mm installed in B501 base
Diameter	102mm installed in B501 base
Weight	115g
Max. Wire Gauge for Terminals	2.5mm ²
Colour	Pantone Warm Grey 1C
Material	Bayblend FR110

Sensitivity Settings

Alarm 1 - Photo-Thermal	High
Alarm 2 - Photo-Thermal	Medium to High - Auto Adjusting
Alarm 3 - Photo-Thermal	Medium
Alarm 4 - Photo-Thermal	Medium to Low - Auto Adjusting
Alarm 5 - Photo-Thermal	Low
Alarm 6 - Thermal Only	Class A1R (58°C)

Product Range

Compatible Bases	B500 Series (B501, B501DG etc)
Other Devices in range	Please refer to other Series 200 <i>plus</i> datasheets